

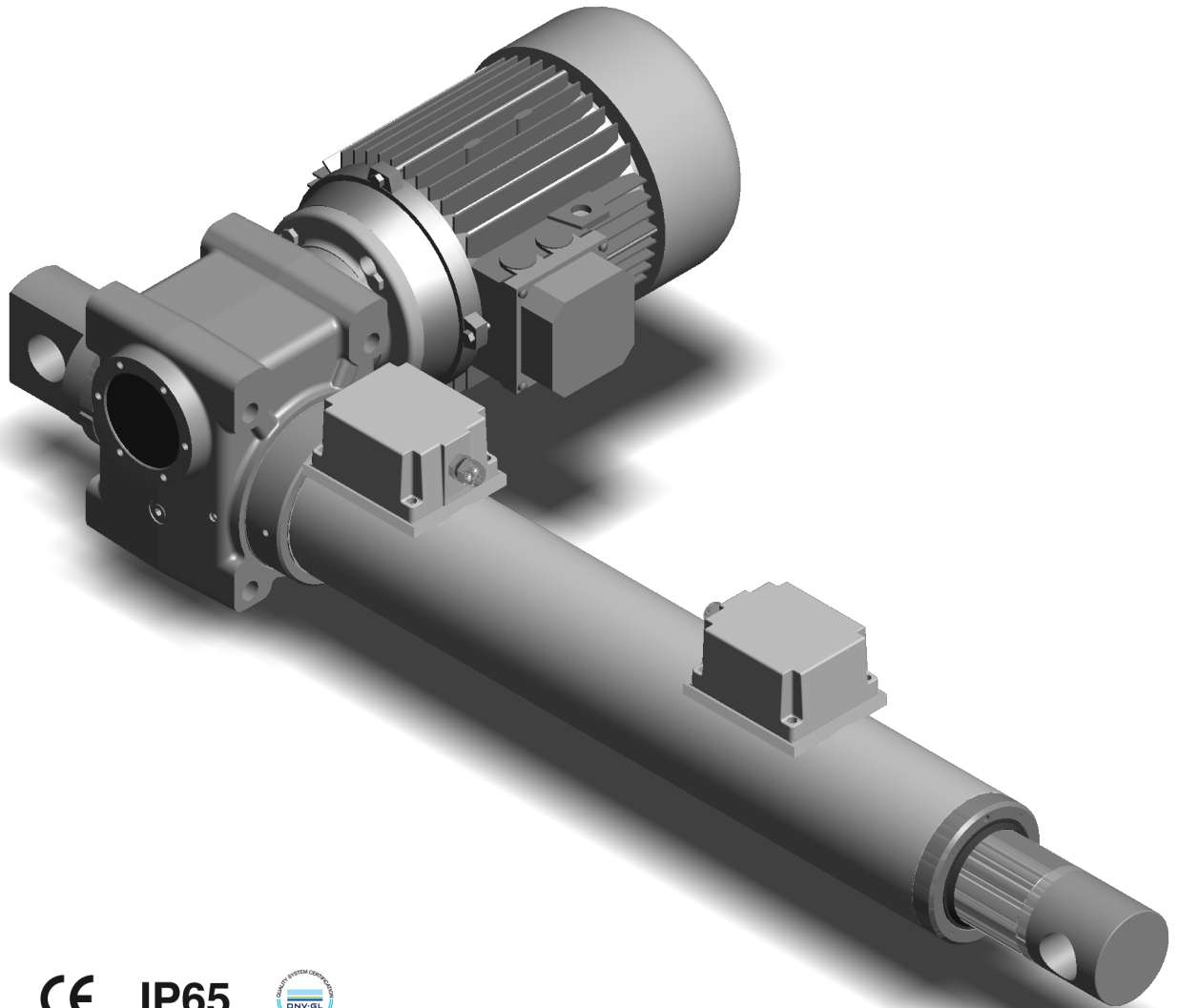

HRS line



CE IP65



MecVel Srl - Via Due Portoni 23 - 40132 - Bologna - Italy

Tel +39 051 4143711 - Fax +39 051 404567

info@mecvel.com - www.mecvel.com

HRS 50 PERFORMANCE - TPN AND VRS VERSIONS

Fmax [N]	Speed [mm/sec]	Version	Motor size - IEC	Power [kW]	rpm	Ratio [i]	Diameter of screw [mm]	Pitch [mm]	Efficiency
HRS50 TPN									
18000	65	M01	IEC112 (bell flange + coupling)	4	1400	5	40	14	0,30 (reversible version)
29000	33	M02	IEC112 (bell flange + coupling)	4	1400	5	40	7	0,24
36500	11	M03	IEC90 (PAM)	2,2	2800	30	40	7	0,18
50000	5	M04	IEC90 (PAM)	1,5	1400	30	40	7	0,18
HRS50 VRS									
30000	47	M01	IEC90 (PAM)	1,8	1400	5	50	10	0,81
45000	23	M02	IEC90 (PAM)	1,5	1400	10	50	10	0,77
50000	7	M04	IEC71 (gear motor)	0,55	2800	10 + 7	50	10	0,64
50000	3	M05	IEC71 (gear motor)	0,25	1400	10 + 7	50	10	0,64

BELL FLANGE + COUPLING VERSION

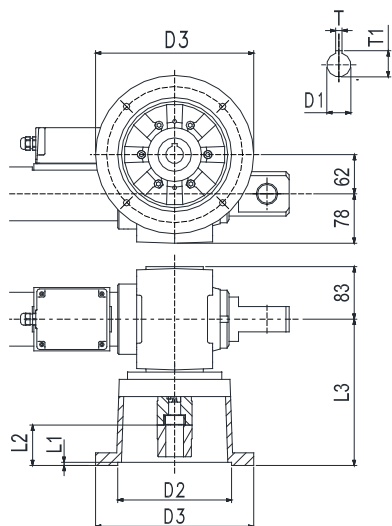

FLAT INPUT MOTOR FLANGE - PAM VERSION

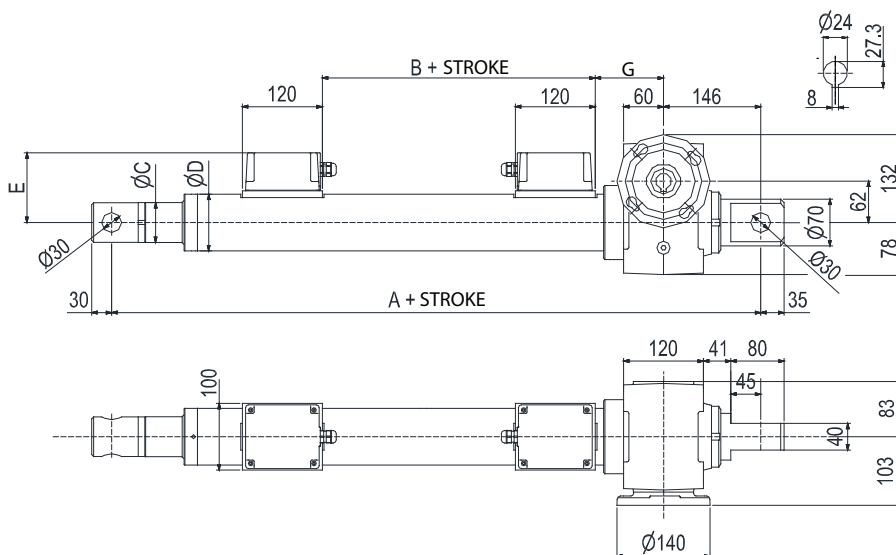

GEAR MOTOR VERSION

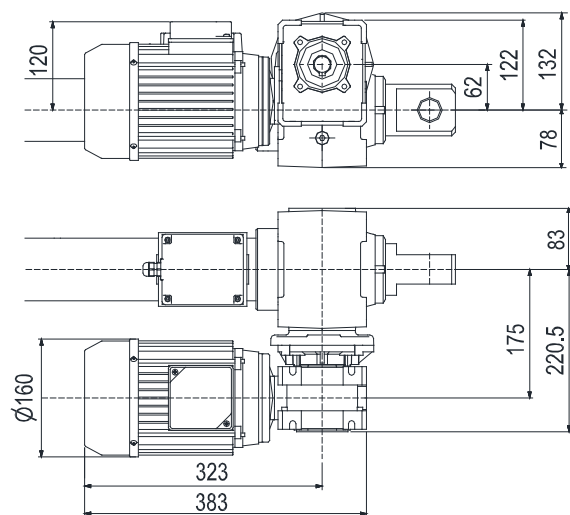

DIMENSIONS	TPN/VRS VERSION	
	HRS 50 TPN	HRS 50 VRS
A	575	715
B	10	112
C	60	70
D	85	140
E	105	132
G	103	121

DIMENSIONS	BELL FLANGE + COUPLING VERSION	
	IEC 90 B5	IEC 100/112 B5
D1	φ24	φ28
D2	φ130	φ180
D3	φ165	φ215
D4	φ200	φ250
F	M10	φ14.5
L1	4.5	5
L2	52	68
L3	183	231
T	8	8
T1	27.3	31.3

HRS 100 PERFORMANCE - TPN AND VRS VERSIONS

Fmax [N]	Speed [mm/sec]	Version	Motor size - IEC	Power [kW]	rpm	Ratio [i]	Diameter of screw [mm]	Pitch [mm]	Efficiency
HRS100 TPN									
38000	42	M01	IEC132 (bell flange + coupling)	7,5	1400	5	55	9	0,21
58000	14	M02	IEC112 (PAM)	5,5	2800	30	55	9	0,16
87000	7	M03	IEC112 (PAM)	4	1400	30	55	9	0,16
100000	2	M04	IEC80 (gear motor P63 ratio 1:7)	1,8	2800	210 (7*30)	55	9	0,16
HRS100 VRS									
51000	47	M01	IEC100 (bell flange + coupling)	3	1400	5	63	10	0,81
70000	23	M02	IEC100 (bell flange + coupling)	2,2	1400	10	63	10	0,77
92000	8	M03	IEC90 (PAM B5)	1,1	1400	30	63	10	0,67
100000	5	M04	IEC71 (gear motor)	0,75	2800	10 + 10	63	10	0,62
100000	2	M05	IEC71 (gear motor)	0,55	2800	30 + 7	63	10	0,55

BELL FLANGE + COUPLING VERSION

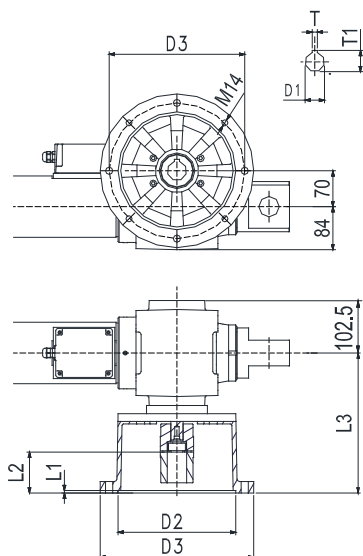

FLAT INPUT MOTOR FLANGE - PAM VERSION

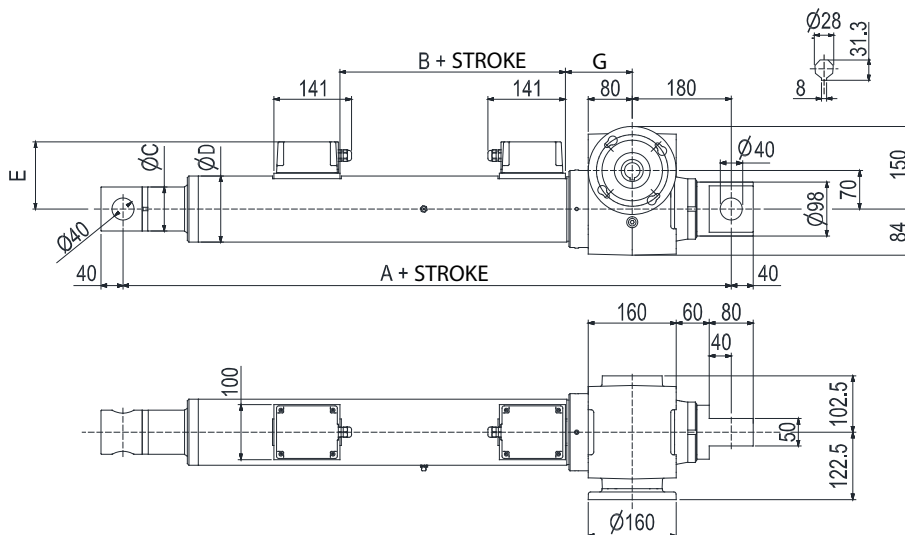

GEAR MOTOR VERSION

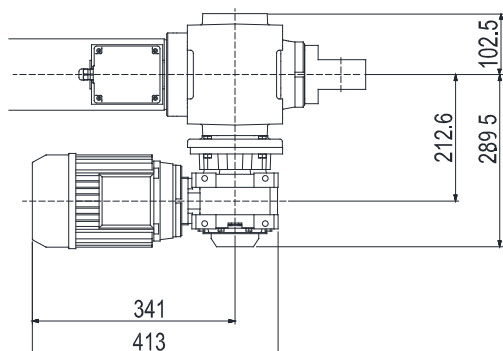
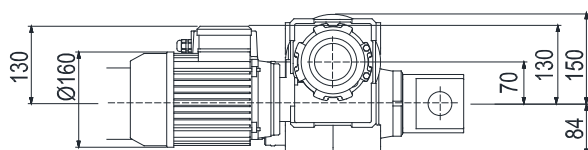

DIMENSIONS	TPN/VRS VERSION	
	HRS 100 TPN	HRS 100 VRS
A	706	780
B	10	133
C	80	80
D	120	150
E	122	137
G	121	141

DIMENSIONS	BELL FLANGE + COUPLING VERSION	
	IEC 100/112 B5	IEC 132 B5
D1	φ28	φ30
D2	φ180	φ230
D3	φ215	φ265
D4	φ250	φ300
F	φ14.5	φ14.5
L1	5	5
L2	68	91
L3	239	274
T	8	10
T1	31.3	41.3

HRS 200 PERFORMANCE - TPN AND VRS VERSIONS

Fmax [N]	Speed [mm/sec]	Version	Motor size - IEC	Power [kW]	rpm	Ratio [i]	Diameter of screw [mm]	Pitch [mm]	Efficiency
HRS200 TPN									
44000	47	M01	IEC132 (bell flange + coupling)	9,2	1400	5	70	10	0,234
90000	16	M02	IEC132 (bell flange + coupling)	7,5	2800	30	70	10	0,1924
130000	8	M03	IEC132 (bell flange + coupling)	5,5	1400	30	70	10	0,1924
200000	2	M04	IEC90 (gear motor P75 ratio 1:7)	2,2	2800	210 (7*30)	70	10	0,1924
HRS200 VRS									
125000	47	M01	IEC132 (bell flange + coupling)	9,2	1400	5	80	10	0,81
174000	23	M02	IEC132 (bell flange + coupling)	5,5	1400	5	80	10	0,77
200000	7	M03	IEC90 (gear motor)	2,2	2800	10 + 7	80	10	0,64
200000	3	M04	IEC90 (gear motor)	2,2	2800	10 + 15	80	10	0,60

BELL FLANGE + COUPLING VERSION

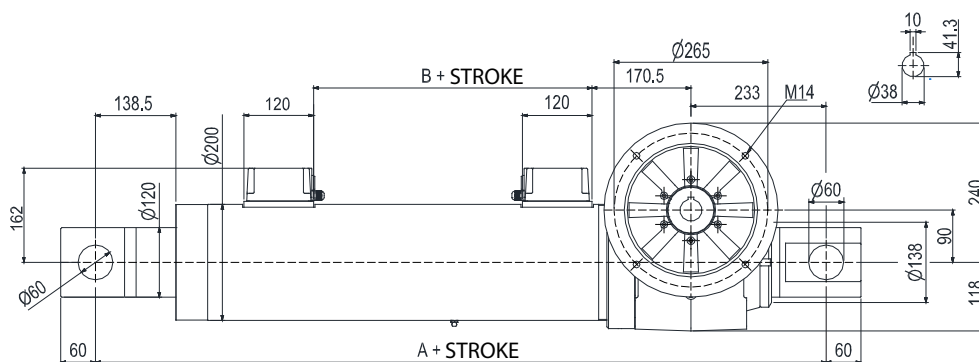

GEAR MOTOR VERSION

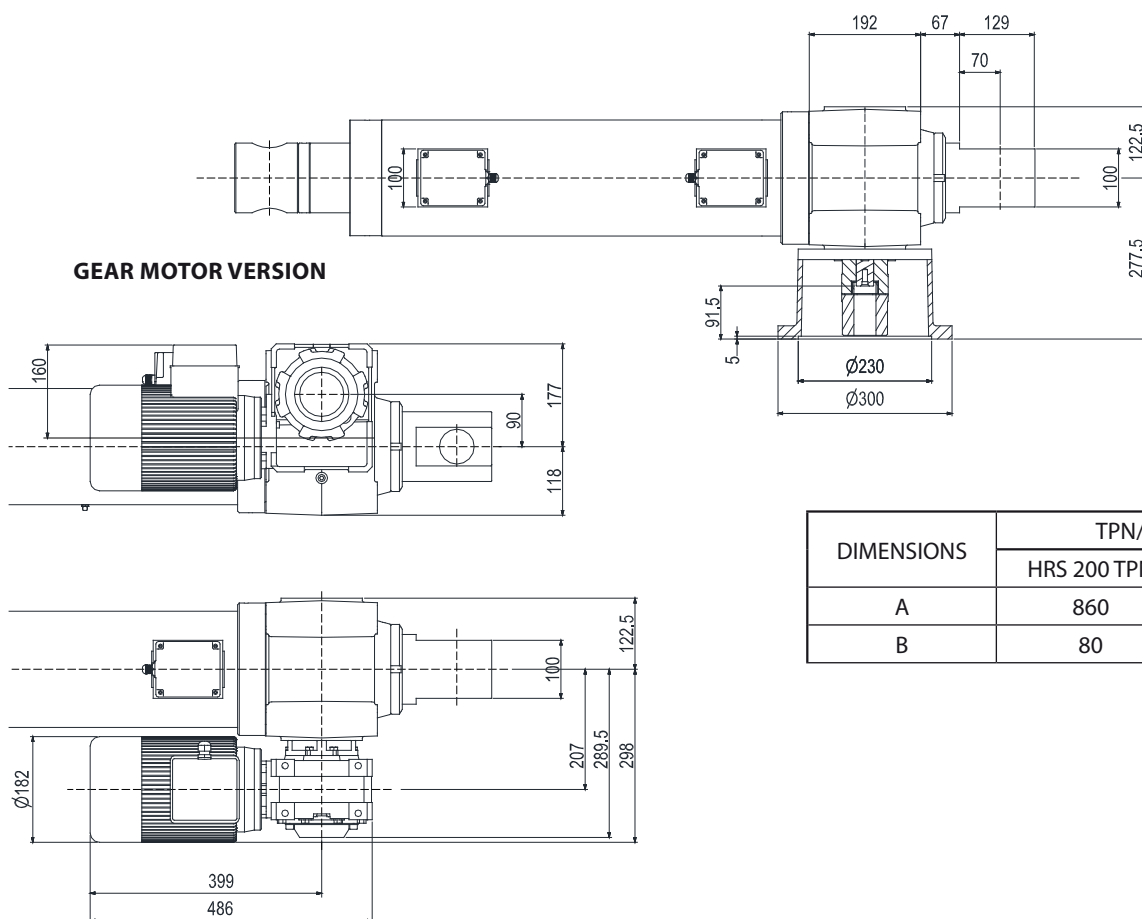

DIMENSIONS	TPN/VRS VERSION	
	HRS 200 TPN	HRS 200 VRS
A	860	996
B	80	142



For motors' sizes it is possible to refer to IEC standard motors – for HRS200 version but also HRS100 and HRS50 versions.

THE BEST EFFICIENCY AND PROTECTION MEET THE HIGHEST LOAD CAPACITY

How to combine the extreme force provided by screw jacks with the high standards in terms of performance and safety offered by electric linear actuators?

MecVel R&D team has developed a new range, designed to give an answer to this request: the HRS line.

The role of linear actuators and screw jacks is to convert the rotatory motion of an electric motor into a linear movement, allowing lifting, adjusting, positioning and rotating of any load simply through a button. These products are characterized by strength and hardness, and are able to give low friction and wear during the handling, together with long life and minimum noise for the whole system.

This range has been created in particular for the heavy industry and outdoor applications, where it is required to face environmental and climatic conditions even critical, and be adaptable to specific needs of use, also thanks to the customization service provided by the company, reflected in the possibility to configure each product following customer requirements. The standard structure of a screw jack is matched with typical linear actuator components, starting from a series of internal guides up to the external cover tube, dedicated to protect and offer a better support in case of buckling. This, together with a great attention for the high quality of the materials involved, allow to reach the same performance of the most powerful screw jacks, also thanks to the use of the most efficient gear boxes. Moreover the best price-quality ratio to join the market in a really competitive way has been maintained.

Technical data

This line is splitted between the version with TPN (acme screw) and the "evolved" version that considers the use of VRS (ball screw), providing a significant increase in terms of performance and higher speed even with the same load. Both these versions are divided in three different "sizes", in order to supply the entire spectrum of possible handlings: HRS 50 for loads up to 50.000 N, HRS 100 for loads up to 100.000 N, HRS 200 for loads up to 200.000 N. Products from this new range can reach speed of 65 mm/s but in this case, in order to avoid the reversibility of the linear actuator, it should be considered to apply a brake, able to keep the load even in static/stop condition, and for all those cases in which precision and repeatability are strongly required.

How to choose the best product according to the kind of application

The duty cycle required by the application is given by the ratio between the working time under load in the stated period, and the stated period itself (10 minutes), expressed in percentage:

- With $F_s \leq 30\%$, a linear actuator with TPN is recommended
- With $F_s \geq 30\%$ a linear actuator with VRS is recommended

One of the main elements, together with the internal mechanisms, is the cover tube, made of steel in order to protect the screw and the whole system from damages due to dust, water and other contaminant external agents, as well as it allows to place limit switch and anti-rotation devices (on request).

Which are other items that it is possible to assemble on these products in order to improve performance and safety level? Bellows boot (on request) as further protection of the screw against contaminant external agents, but also flanges, bell flanges and couplings, dedicated to combine three-phase electric motors and servomotors (at 90° or parallel to the linear actuator, for a further reduction of the overall dimensions), allowing the customer to choose freely the motor to apply. The supply of a gear motor allows to provide a reduced torque and consequently to decrease the time needed to complete the stroke up to 2 mm/sec, in order to reach the speed required in the photovoltaic field for example, reducing at the same time the energy consumption.

The electric system proposed by MecVel is a perfect match between mechanical and electric components, and it is able to provide excellent performance when compared to pneumatic and hydraulic ones. This eco-friendly system, in fact, has easy and essential connections, avoids pumps, valves and pipes, excluding the risk of contamination due to oil leaks, provides power only when required and reliable control such as arrests in intermediate positions. Moreover it offers the possibility to work with high temperature, dust and vibration requiring very little maintenance.

This new range proposed by MecVel is characterized by great innovation and efficiency, where each product is designed to improve and make unique every handling.

